

Single-Point Aluminum Load Cell

FEATURES

- Capacities: 5–30 kg
- Only 22 mm high
- Aluminum construction
- Single-point 350 x 350 mm platform
- IP66 protection
- OIML R60 and NTEP approved (pending)
- Optional
 - ATEX, FM and IECEx approvals available
 - Symmetric configuration available



APPLICATIONS

- Bench scales
- Counting scales
- Grocery scales

DESCRIPTION

The Model 1022 is a low profile single-point load cell designed for direct mounting in low cost weighing platforms.

Its small physical size, combined with high accuracy and aluminum construction, makes this low cost load cell ideally suited for retail, bench and counting scales.



Using Model 1022 load cells simplifies scale construction, which results in significant parts and labor savings.

High impedance makes this model uniquely suitable for battery operated scales.

The Model 1022 is available in a range of capacities: 5 to 30 kg, Approved to OIML and NTEP standards (pending). Environmental protection to IP66 is provided as standard. For hazardous environments, ATEX, FM and IECEx approvals available.

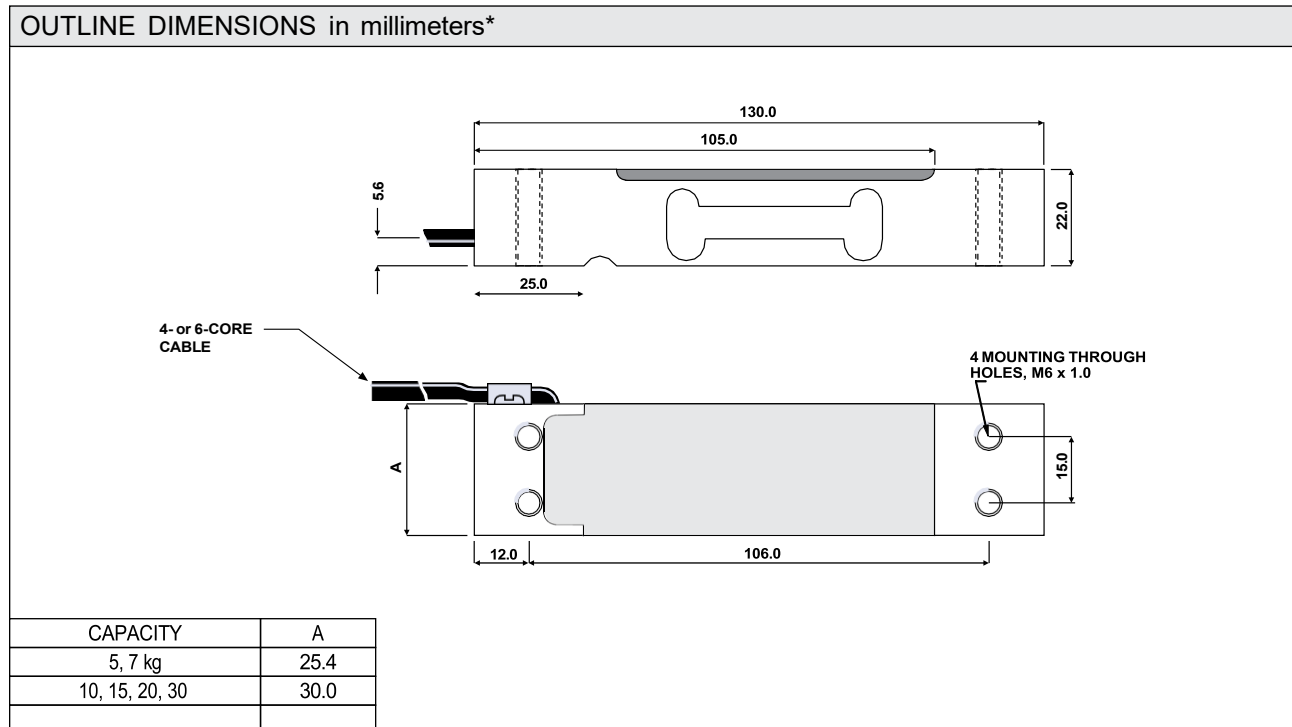

* Double-sided bonding is available on request

Single-Point Aluminum Load Cell

SPECIFICATIONS					
PARAMETER	VALUE				UNIT
Rated capacity—R.C. (E_{max})	5, 7, 10, 15, 20, 30				kg
NTEP/OIML accuracy class	NTEP	Non-Approved	C3*	C4	
Maximum no. of intervals (n)	5000 single**	1000	3000	4000	
$Y = E_{max}/V_{min}$	10000	1400	6000	10000	Maximum available 10000
Rated output—R.O.	2.0				mV/V
Rated output tolerance	0.2				±mV/V
Zero balance	0.1				±mV/V
Zero return, 30 min.	0.01	0.05	0.0170	0.0125	±% of applied load
Total error (per OIML R60)	0.0200	0.03	0.0200	0.0150	±% of rated output
Temperature effect on zero	0.0014	0.0100	0.0023	0.0014	±% of rated output/°C
Temperature effect on output	0.0010	0.0030	0.0010	0.00075	±% of rated output/°C
Eccentric loading error	0.0057	0.0085	0.0057	0.0042	±% of rated load/cm
Temperature range, compensated	-10 to +40				°C
Temperature range, safe	-30 to +70				°C
Maximum safe central overload	150				% of R.C.
Ultimate central overload	300				% of R.C.
Excitation, recommended	10				VDC or VAC RMS
Excitation, maximum	15				VDC or VAC RMS
Input impedance	4500+5500				Ω
Output impedance	4400+5500				Ω
Insulation resistance	>2000				MΩ
Cable length	0.5, other lengths available				m
Cable type	Std. Opt. Opt.	4 wire, PVC, Floating screen 6 wire Grounded screen			
Construction	Aluminum				
Environmental protection	IP66				
Platform size (max.)	350 × 350				mm
Recommended torque	7.0				N*m

* 50% utilization

** Also available at 50% utilization

All specifications subject to change without notice.

WIRING SCHEMATIC DIAGRAM****

(Unbalanced bridge configuration)

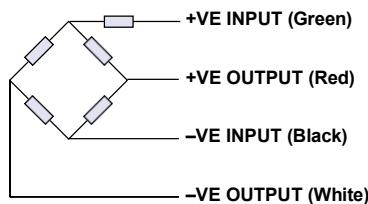

**** Balanced bridge available with 6 sense wires

Disclaimer

ALL PRODUCTS, PRODUCT SPECIFICATIONS AND DATA ARE SUBJECT TO CHANGE WITHOUT NOTICE.

Vishay Precision Group, Inc., its affiliates, agents, and employees, and all persons acting on its or their behalf (collectively, "VPG"), disclaim any and all liability for any errors, inaccuracies or incompleteness contained herein or in any other disclosure relating to any product.

The product specifications do not expand or otherwise modify VPG's terms and conditions of purchase, including but not limited to, the warranty expressed therein.

VPG makes no warranty, representation or guarantee other than as set forth in the terms and conditions of purchase. To the maximum extent permitted by applicable law, VPG disclaims (i) any and all liability arising out of the application or use of any product, (ii) any and all liability, including without limitation special, consequential or incidental damages, and (iii) any and all implied warranties, including warranties of fitness for particular purpose, non-infringement and merchantability.

Information provided in datasheets and/or specifications may vary from actual results in different applications and performance may vary over time. Statements regarding the suitability of products for certain types of applications are based on VPG's knowledge of typical requirements that are often placed on VPG products. It is the customer's responsibility to validate that a particular product with the properties described in the product specification is suitable for use in a particular application. You should ensure you have the current version of the relevant information by contacting VPG prior to performing installation or use of the product, such as on our website at vpgsensors.com.

No license, express, implied, or otherwise, to any intellectual property rights is granted by this document, or by any conduct of VPG.

The products shown herein are not designed for use in life-saving or life-sustaining applications unless otherwise expressly indicated. Customers using or selling VPG products not expressly indicated for use in such applications do so entirely at their own risk and agree to fully indemnify VPG for any damages arising or resulting from such use or sale. Please contact authorized VPG personnel to obtain written terms and conditions regarding products designed for such applications.

Product names and markings noted herein may be trademarks of their respective owners.

Copyright Vishay Precision Group, Inc., 2014. All rights reserved.